



WC

Montage pour kit plaque coupe-feu
réf. : WBSKITCF

NOTICE

5

Coller le petit ruban intumescent autour des fûts des actionneurs.

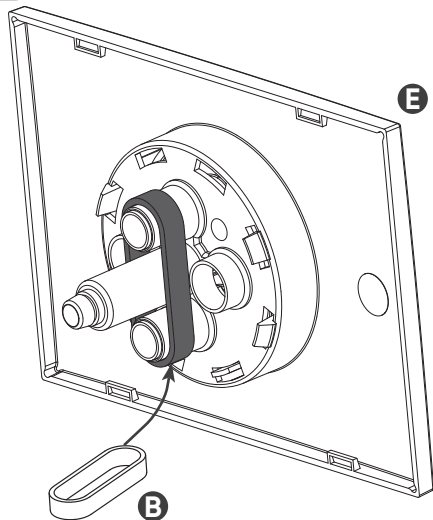

6

Emboîter le bloc coupe-feu sur l'arrière de la plaque.

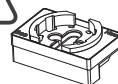
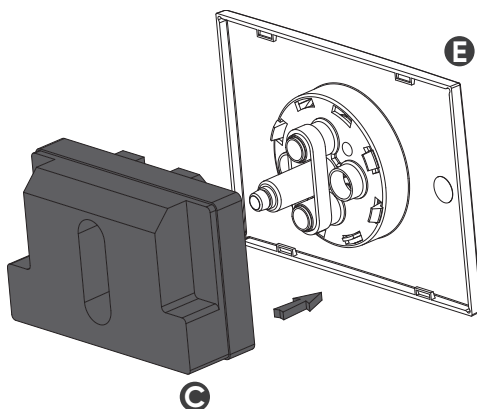

Respecter le sens d'insertion du bloc coupe feu en s'aidant du marquage en face avant

7

Fixer et verrouiller le boîtier de commande à la plaque de commande.

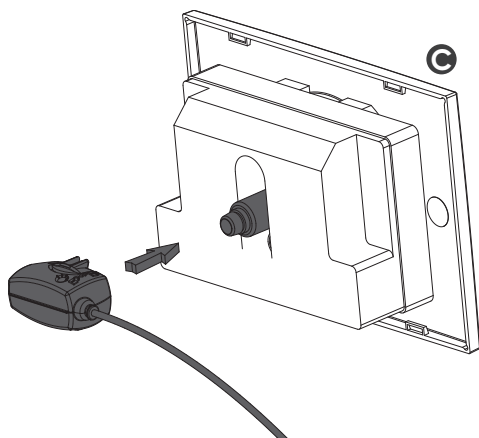

8

Assembler la plaque de commande sur le support de plaque.

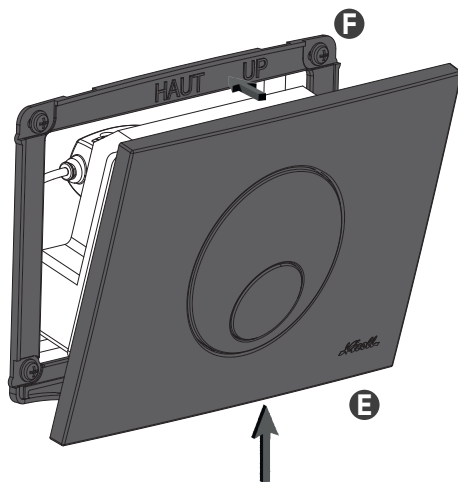

9866996-02/25 - Document non contractuel.